



SCOTT'S – BELL 47, INC.

April 10, 2015

INFORMATION LETTER 47-15-11

To: All Owners/Operators of Bell 47 Helicopters who have acquired STC SH2772SW or P/N 74-140-914-31 originally shipped from the Texas Helicopter Company, Inc. between July 1, 2013 and October 21, 2014.

Subject: Inspection/Repair of P/N 74-140-914-31

Compliance: Perform compliance procedure before next flight but no later than 30 days from release date of this Information Letter.

Scott's – Bell 47, Inc. (SB47) was recently informed that an aircraft part, for which SB47 is now supporting continued airworthiness, may have been incorrectly assembled.

The suspect part was manufactured and sold by Texas Helicopter Company, Inc., between July 1, 2013 and October 21, 2014. SB47 has acquired the Supplemental Type Certificate incorporating this part. SB47 is not the manufacturer of the suspect parts but will gladly support operators using these parts to resolve the situation as quickly as possible.

The suspect part is the "Idler Lever Assembly", P/N 74-140-914-31. This lever is a component of STC SH2772SW, also known as the "No Bar Kit". Each STC Kit contains two Idler Lever Assemblies.

It has been determined that the pivot bearings may have been incorrectly installed, preventing the bearings from receiving proper lubrication.

SB47 sees this potential manufacturing deficiency as flight safety critical and is currently working with all levels of the FAA to help remedy this situation as quickly and easily as possible. To accomplish this, SB47 is releasing the following procedure to all former Texas Helicopter Company, Inc. customers who have received the suspect parts:



SCOTT'S – BELL 47, INC.

Procedure to comply with Information Letter 47-15-11

- a) Remove both suspect Idler Lever Assemblies from the aircraft (if installed).
- b) Ship the two suspect Idler Lever Assemblies to SB47 at the following address:

Scott's – Bell 47, Inc.
Attn.: Idler Levers
100 Minnesota Ave.
Le Sueur, MN 56058

- c) SB47 will have the parts inspected and, if necessary, repaired within 4 days of receipt with no charge to the customer.
- d) SB47 will ship the parts back to the sender with no charge to the customer.
- e) Install the Idler Lever Assemblies as per STC Installation Instructions.
- f) Make the appropriate logbook entry in the aircraft maintenance records that shows this Information Letter has been complied with.

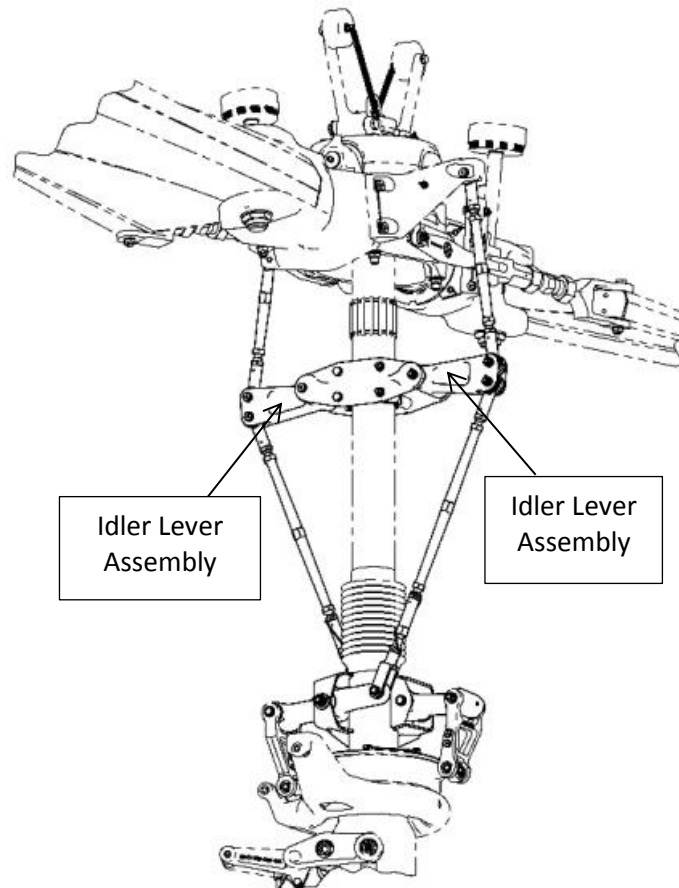

Fig. 1: Location of Idler Lever Assembly